



THE NEW GLC COUPÉ

Mercedes-Benz





PACKED WITH PASSION.

The new GLC Coupé combines power and design in a single, comfortable vehicle concept.

The width of the radiator grille and its optional running boards leave no room for doubt about its dynamic nature. With innovative assistance systems¹, plus High Performance headlamps as standard and DIGITAL LIGHT on request, it cuts a fine figure everywhere.

¹Our driver assistance and safety systems are aids and do not relieve you of your responsibility as a driver. Please take note of the information in the Owner's Manual and the system limits which are described therein.

FEELS LIMITLESS.
THOUGHT-THROUGH DOWN TO
THE SMALLEST DETAIL.

A generous promise of driving enjoyment, which the unique form of the new GLC Coupé, with its load capacity and stowage options, makes suitable for everyday use. A highlight: the restyled two-piece bicolour rear lamps. These have a three-dimensional interior, and are also available with a light animation option.





**INSIDE THE CAR,
ALL THE ATTENTION IS ON YOU.**

Everything in the new GLC Coupé is geared towards you. The central display of the digital cockpit with touchscreen is inclined towards the driver and is the digital interface between you and the vehicle, through which you control many important functions of the vehicle – intuitively and comfortably. The AMG sports steering wheel (optional in the AMG Line interior) not only sits well in your hands, but is also a feast for your eyes. Just like the instrument panel, it features a high-quality finish.

INTELLIGENT HYBRID TECHNOLOGIES TAKE YOU EVEN FURTHER INTO THE FUTURE.

Economical combustion engines, combined with an efficient electric drive, ensure lower emissions. Zero-emission zones or city areas are detected by the system, so you drive with zero local CO₂ emissions through the city centre and yet have no need to compromise on comfort even on long journeys.



FLEXIBLE CHARGING OPTIONS.

As a plug-in hybrid, the new GLC Coupé offers you various charging options for the high-voltage battery. Whether you decide on a socket or the Wallbox: thanks to increased electrical output and improved efficiency, the range has been increased to more than 100 km (WLTP).



The image shows the front interior of a Mercedes-Benz GLC Coupé. The driver's seat is in the foreground, featuring a light-colored perforated leather upholstery. The passenger seat is visible behind it. The dashboard and center console are dark with silver accents. The steering wheel is black with silver trim. The instrument cluster and infotainment screen are illuminated. The overall atmosphere is modern and luxurious.

FEEL-GOOD ATMOSPHERE INCLUDED.

Even the base variant of the new GLC Coupé is equipped with the Seat Comfort Package. Electric operation makes the various seat functions easy to control. Integrated head restraints help you to relax. The ambient lighting ensures a special feel-good atmosphere, both by day and at night.



In the fast lane digitally, too.

The new MBUX multimedia system now networks your driving experience even better: you can control many important functions of the vehicle intuitively and comfortably. Individual user profiles¹ make your favoured radio stations, playlists or navigation routes immediately accessible.

¹The components marked with "1" are Mercedes me services. A personal Mercedes me ID and agreement to the Terms of Use for the Mercedes me connect services are required to use these services. In addition, the vehicle must be paired with the corresponding user account. Upon expiry of the initial one-year term, the services can be renewed for a fee, provided they are still offered for the corresponding vehicle at that point. Initial activation of the services is possible within 1 year of initial registration or operation by the customer, whichever comes first.



Always by your side: the driving assistance systems.

The latest generation of Intelligent Drive assistance systems¹ stands ready for use in the new GLC Coupé. With partially automated driving the driver is relieved, supported and protected. PRE-SAFE® Impulse Side offers additional protection in side collisions. The transparent bonnet can show a virtual view of the area directly in front of your Mercedes during off-road journeys, calculated from camera images. This means that you can manoeuvre with confidence and assurance, and safely avoid obstacles – even in rough terrain.

¹Our driver assistance and safety systems are aids and do not relieve you of your responsibility as a driver. Please take note of the information in the Owner's Manual and the system limits which are described therein.



DIGITAL LIGHT makes everything clear.

Lighting adapted to the driving situation, for relaxed and safe driving: DIGITAL LIGHT¹ constantly adapts the illumination of the road ahead for you to the lighting conditions, traffic situation, the course of the road and the weather. The HD system works like a projector and calculates the lighting accurately down to the last pixel.

¹Optionally selectable equipment depending on configuration.

A new definition of freedom.

The panoramic sliding sunroof¹ of the new GLC Coupé has been enlarged thanks to lateral guidance for the sunblind. This enables you to enjoy an even better outlook from an interior that is bathed in light.

Clear information in advance.

With the head-up display¹ you have important information such as speed, speed limit, warning messages and navigation instructions in direct line of sight, so you need never take your eyes off the road. The head-up display can be ergonomically adjusted and the individual setting can be saved in the user profile.

¹Optionally selectable equipment depending on configuration.

Brilliant sound.

The exclusive Burmester® 3D surround sound system¹ and 15 high-quality speakers with a total output of 710 watts ensure you get to enjoy impressive all-round sound. This can be set freely and precisely for the front and rear seats. The high-quality finish also makes the sound system a visual pleasure.

Exclusive AVANTGARDE standard equipment.

The new GLC Coupé comes with AVANTGARDE: on the exterior that means LED headlamps and a chrome-trimmed radiator grille. In the interior, high quality materials were used. Five colours are available for selection in a nappa look and with seams that give the impression of being hand-stitched.

¹Optionally selectable equipment depending on configuration.



Maximally sporty with AMG.

The expressive styling that is all part of the AMG Line¹ lends the GLC Coupé a sporty, exclusive touch: with sporty surfaces on the beltlines, flared wheel arch linings in the vehicle colour and a three-spoke steering wheel, which has a diameter of just 370 mm.

Night Package¹.

With this equipment package, many of the details of the new GLC Coupé are finished in high-gloss black: the louvre in the radiator grille with Mercedes-Benz pattern, the AMG light-alloy wheels, the AMG front apron and the outside mirror housing. The roof railing in matt black represents the crowning glory.

¹Optionally available in conjunction with the AMG Line.





GLC 300 de 4MATIC.

The new GLC Coupé with plug-in hybrid technology combines the high range of the combustion engine with the dynamic efficiency of an electric motor.

GLC 300 de 4MATIC | WLTP | Combined fuel consumption, weighted: **XX.X** l/100 km; combined electric energy consumption, weighted **XX** kWh/100 km; combined CO₂ emissions, weighted **XX** g/km¹. GLC 300 e 4MATIC | WLTP | Combined fuel consumption: **X.X-X.X** l/100 km; combined CO₂ emissions: **XX-XX** g/km; combined electric energy consumption: **XX.X-XX.X** kWh/100 km¹. GLC 400 e 4MATIC | WLTP | Combined fuel consumption, weighted: **XX.X** l/100 km; combined power consumption, weighted **XX** kWh/100 km; combined CO₂ emissions, weighted **XX** g/km¹.

GLC 300 e 4MATIC and GLC 400 e 4MATIC.

The new GLC Coupé with plug-in hybrid technology: with even more electric output, improved efficiency and shorter charging times, you can enjoy the sort of driving fun that points to the future.

Effortlessly superior and agile at the same time: The rear axle steering.

An electromechanical rear axle steering¹ system is offered as an option. At low and medium speeds it ensures a more agile driving style and more manoeuvrability by enabling a 90 cm smaller turning circle. At higher speeds it brings more stability.

Dynamism and comfort rolled into one with AIRMATIC.

The AIRMATIC air suspension¹ automatically ensures sporty vehicle dynamics or enhanced ride comfort, so you can drive your GLC Coupé in either a sportily intensive or a gently comfortable style.

¹The stated figures are the determined "WLTP CO₂ figures" pursuant to Article 2 No. 3 of Implementing Regulation (EU) 2017/1153. Fuel consumption figures have been calculated on this basis. Power consumption and range have been determined on the basis of Directive (EU) 2017/1151.

¹Optionally available with the Engineering Package.

Technical data.

Displacement (cc)
Rated output ¹ (kW [hp] at rpm)
Acceleration from 0 to 100 km/h (s)
Top speed (km/h)
Fuel consumption ⁴ (l/100 km)
Urban
Extra-urban
Combined
Combined CO ₂ emissions ⁴ (g/km)
Emissions class ⁵ /Efficiency class ⁶

Diesel engines

XXX	XXX
XXX	XXX
XXX	XXX
XXX ³	XXX ³
XXX	XXX
XXX	XXX
XXX	XXX
XXX	XXX
XXX	XXX

Petrol engines

XXX	XXX
XXX ²	XXX ²
XXX	XXX
XXX ³	XXX ³
XXX	XXX
XXX	XXX
XXX	XXX
XXX	XXX
XXX	XXX

Plug-in hybrid engine

XXX
XXX ²
XXX
XXX ³
XXX
XXX
XXX
XXX

The best for the engine:
Mercedes-Benz genuine engine oils.

¹ Figures for rated output in accordance with Regulation (EC) No. 715/2007 in the currently applicable version. ² Available for a brief period. ³ Electronically governed. ⁴ The figures shown were calculated according to the prescribed measuring method. They constitute the "NEDC CO₂ figures" pursuant to Article 2 No. 1 of Implementing Regulation (EU) 2017/1153. Fuel consumption figures have been calculated on this basis. More information about the official fuel consumption and the official specific CO₂ emissions of new passenger cars is available in the publication entitled "Leitfaden über den Kraftstoffverbrauch, die CO₂-Emissionen und den Stromverbrauch neuer Personenkraftwagen" ["Guide on the fuel economy, CO₂ emissions and power consumption of all new passenger car models"], available free of charge at all retailers and from Deutsche Automobil Treuhand GmbH at www.dat.de. The figures are not based on an individual vehicle and do not constitute part of the product offer; they are provided solely for the purpose of comparison between different vehicle models. The figures will vary according to the selected optional features. ⁵ Information only valid within the European Union. Details may vary from country to country. ⁶ Calculated on the basis of the measured CO₂ emissions, taking into consideration the vehicle mass. Valid for Germany only. For further technical data, please visit www.xxxxxx.xxx

Dimensions.

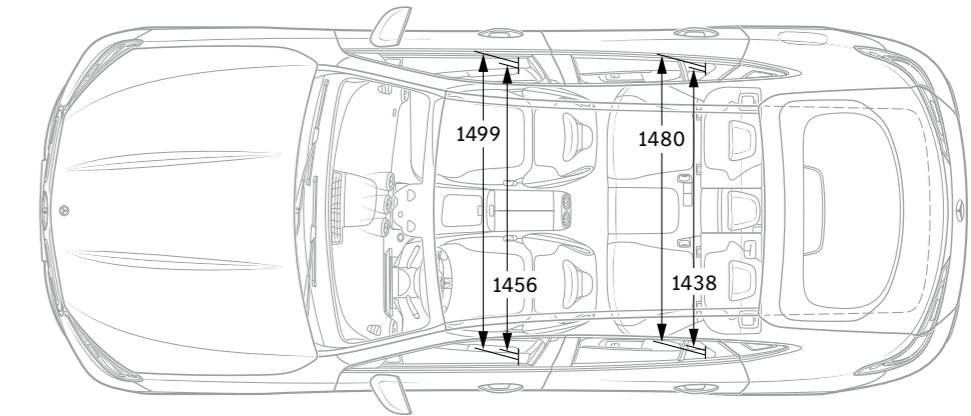
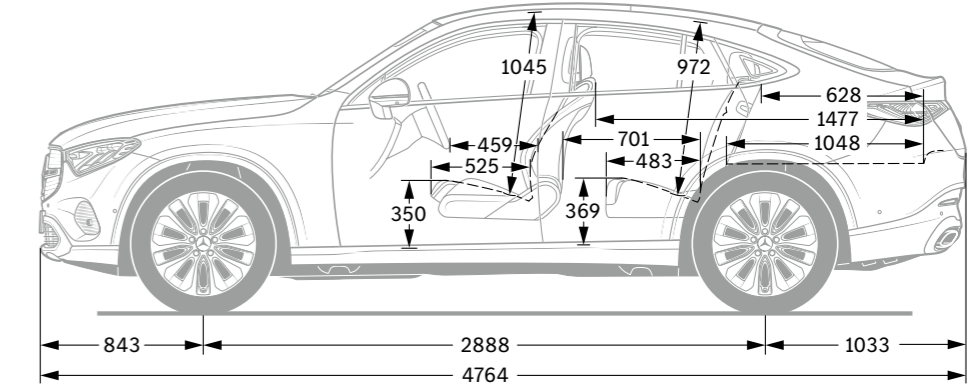
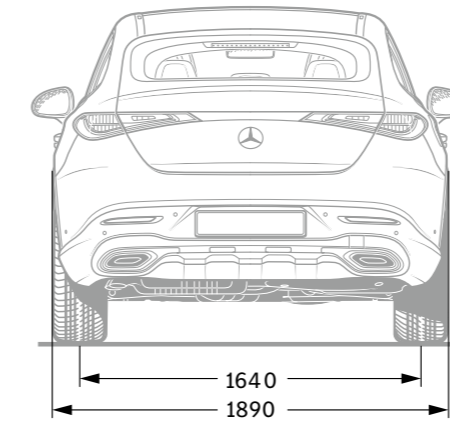
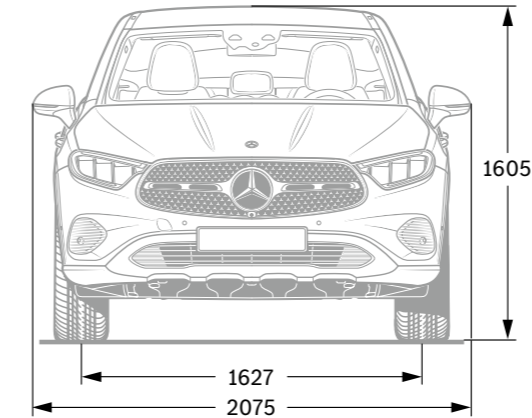

All figures in millimetres. The dimensions shown are mean values. They are valid for vehicles with standard equipment and in unladen condition.

Please note: changes may have been made to the product since the editorial deadline (07.06.2023). The manufacturer reserves the right to make changes to the design, form, colour and the product specification during the delivery period, provided these changes, while taking into account the interests of the vendor, can be deemed reasonable with respect to the purchaser. Where the vendor or the manufacturer uses symbols or numbers to describe an order or the subject of an order, no rights may be derived solely from these. The illustrations may show accessories and items of optional equipment which are not part of standard specification.

XXXXXXX, XXXXXXX@XXXXXX.XXX, 02-0223

This publication is distributed internationally. However, information regarding statutory regulations, legal requirements and taxation and the consequences thereof applies to the Federal Republic of Germany only and is correct at the time of the editorial deadline. For the definitive latest information, please contact your nearest authorised Mercedes-Benz AG sales partner.

www.xxxxxx.xxx