

# The C-Class Saloon



Mercedes-Benz



Welcome to the comfort zone.

Sporty elegance, innovative safety technology and a luxurious interior make the new C-Class Saloon your comfort zone.





## The design: sportiness meets modern luxury.

The exterior design is defined by clean lines and elaborately sculpted surfaces. This minimalistic design idiom brings together luxury and sportiness with ease. The dynamic front section, an extended wheelbase and sporty powerdomes give the new C-Class its clear forward thrust.



## The interior: the expression of progressive comfort.

The digital cockpit, the large touchscreen in the centre console and a progressive concept for the trim make it absolutely clear: the new C-Class Saloon embodies modern luxury.

## The drive system: innovative and efficient.

In the new Mercedes-Benz C-Class Saloon you will find the latest-generation petrol and diesel engines. The innovative technology, featuring an integrated starter-generator, makes the new C-Class agile and effortlessly superior when accelerating.





## Climb in. Breathe out.

The extensive comfort highlights in the new C-Class Saloon relax you from the very first second. From the multicontour seats with eight massage programs and the impressive ambient lighting concept through to the pioneering ENERGIZING Packages. They all add up to make your new C-Class an oasis of relaxation in every situation.

The safety:  
reassuringly Mercedes-Benz.

The intelligent safety concept in the new C-Class Saloon is pioneering. The many innovations make every journey pleasant and safe. The updated Driving Assistance Package thinks for itself. And above all: of you. The centre airbag and PRE-SAFE® Impulse Side are further safety features designed for your protection.





## Modern luxury: digital first.

Progressive voice control and a multimedia system that learns from and with you. The further development of the most innovative control system MBUX makes your new C-Class Saloon a digital comfort zone. Its pioneering features include Augmented Video Navigation and the enlarged head-up display.



## Thinks for itself and, above all: of you.

A comfort zone in which you can fully and completely relax, even in stressful situations such as in a traffic jam. The innovative safety and assistance systems in the new C-Class Saloon are all part of this. The progressive PRE-SAFE® Impulse Side and the Driving Assistance Package can protect you when it matters.





## ENERGIZING Packages.

The ENERGIZING Packages make your relaxation their top priority. Choose from different mood modes such as “Vitality” or “Refresh”, or one of the three training programs.

## Ambient lighting.

The lighting concept extends from the centre console through the entire vehicle. 64 colour schemes alternate dynamically or light up various areas of the new C-Class in different colours. Lean back and relax.

## DIGITAL LIGHT with projection.

The high-resolution DIGITAL LIGHT adapts optimally to any situation and at the same time ensures more comfort. Various light functions react to the surroundings as well as to other road users and help ensure ideal light conditions.

## Multicontour seats for driver and front passenger.

Tailor-made to pamper you: these seats combine a wealth of adjustment options with exclusive feel-good extras. Ergonomic details enable you to adopt a perfect seating position: inflatable side cushions ensure strong lateral support. Pleasant massage functions with up to six different programs make every journey a pleasure.

## The AVANTGARDE design and equipment line.

With the AVANTGARDE exterior and interior you can further enhance the individuality and sportiness of your vehicle – and demonstrate clearly the importance that you attach to style and high quality. The interplay between the exterior design features results in an extraordinarily expressive vehicle. The lowered suspension offers the ideal balance between dynamism, comfort and safety. The avant-garde highlights in the expressively styled interior with ambient lighting will bring you joy day after day.



## The AMG Line.

The expressive bodystyling of the AMG Line lends a sporty, exclusive touch to both the exterior and the interior of the C-Class. In this way, you make a clear statement for powerful design. Tangibly enhanced driving pleasure is offered by a series of special technical features, among them the agile sports suspension with Sports Direct-Steer (not for plug-in hybrid models). In the interior you show at first glance what matters to you: an ambience that is dynamic and exclusive in every detail.



## Standard equipment and appointments.

The standard exterior is highly attractive from any angle and focuses on timeless attractiveness. The striking design elements include powerdomes on the bonnet, LED High Performance headlamps and 43.2 cm (17-inch) light-alloy wheels. With the standard interior you are opting for timeless appeal. High-quality interior lighting and extensive stowage facilities bring the brand's hallmark comfort to the standard equipment.



## The Night Package.

The Night Package adds attractive touches: many of the exterior features are finished in black. They underscore the sporty character and special individuality of your vehicle, thereby allowing you to demonstrate your sense of expressive design and exclusive sportiness.





## Suspension with Adaptive Damping System.

One suspension, three set-ups. The suspension with Adaptive Damping System adjusts to your driving style. Do you prefer relaxed ride comfort or high agility? Use the DYNAMIC SELECT switch to move swiftly through different modes such as “Comfort” and “Sport”.



## Integrated starter-generator.

Performance meets efficiency: between the engine and transmission in the new C-Class there is a second-generation integrated starter-generator. This innovative system takes on the function of a hybrid assist motor. It enables additional torque of up to 200 Nm to be called up during acceleration.

## Technical data.

Displacement (cc)
Rated output <sup>1</sup> (kW [hp] at rpm)
Acceleration from 0 to 100 km/h (s)
Top speed (km/h)
Fuel consumption <sup>4</sup> (l/100 km)
Urban
Extra-urban
Combined
Combined CO <sub>2</sub> emissions <sup>4</sup> (g/km)
Emission class <sup>5</sup> /Efficiency class <sup>6</sup>

### Diesel engines

XXX	XXX	XXX
XXX		
XXX		
XXX		
XXX <sup>3</sup>		
XXX		
XXX		
XXX		
XXX		
XXX		
XXX		

### Petrol engines

XXX	XXX
XXX	
XXX <sup>2</sup>	
XXX	
XXX <sup>3</sup>	
XXX	
XXX	
XXX	
XXX	
XXX	
XXX	

The best for the engine:  
Mercedes-Benz genuine engine oils.

<sup>1</sup> Figures for rated output in accordance with Regulation (EC) No. 715/2007 in the currently applicable version. <sup>2</sup> Available for a brief period. <sup>3</sup> Electronically limited. <sup>4</sup> The figures shown were calculated according to the prescribed measuring method. They constitute the "NEDC CO<sub>2</sub> figures" pursuant to Article 2 No. 1 of Implementing Regulation (EU) 2017/1153. Fuel consumption figures have been calculated on this basis. More information about the official fuel consumption and the official specific CO<sub>2</sub> emissions of new passenger cars is available in the publication entitled "Leitfaden über den Kraftstoffverbrauch, die CO<sub>2</sub>-Emissionen und den Stromverbrauch neuer Personenkraftwagen" ["Guide on the fuel economy, CO<sub>2</sub> emissions and power consumption of all new passenger car models"], available free of charge at all retailers and from Deutsche Automobil Treuhand GmbH (www.dat.de). The figures are not based on an individual vehicle and do not constitute part of the product offer; they are provided solely for purposes of comparison between different vehicle models. Figures will vary according to the optional equipment selected. <sup>5</sup> Information valid within the European Union only. May vary from country to country. <sup>6</sup> Determined on the basis of the measured CO<sub>2</sub> emissions, taking into consideration the vehicle mass. Valid for Germany only. For further technical data, please visit [www.xxxxxx.xxx](http://www.xxxxxx.xxx)

## Dimensions.

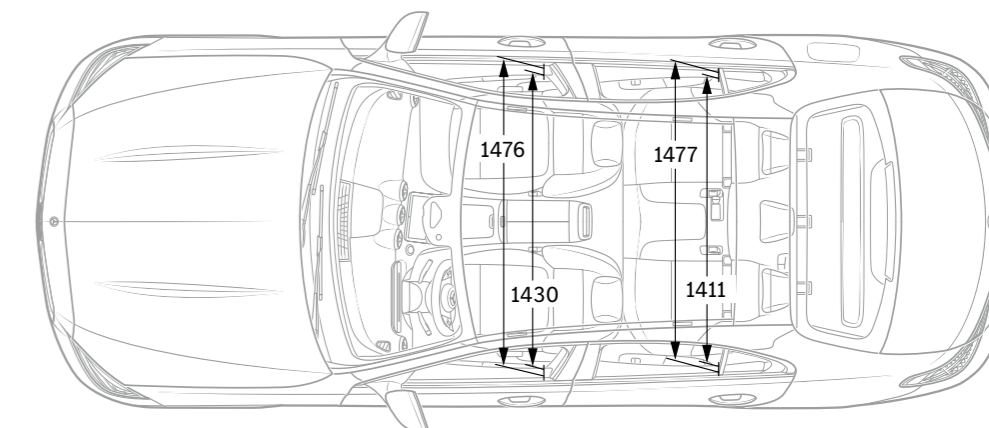
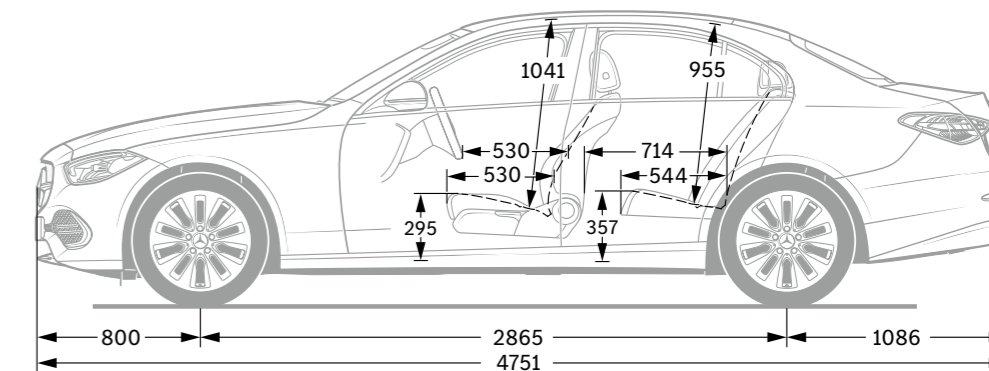
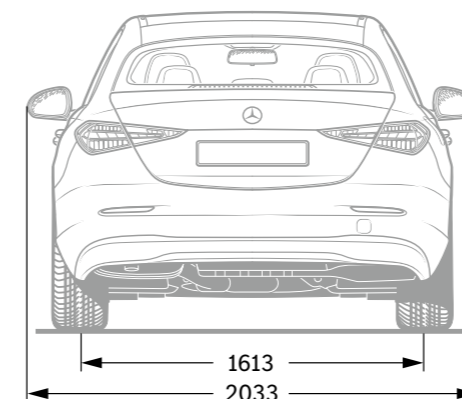
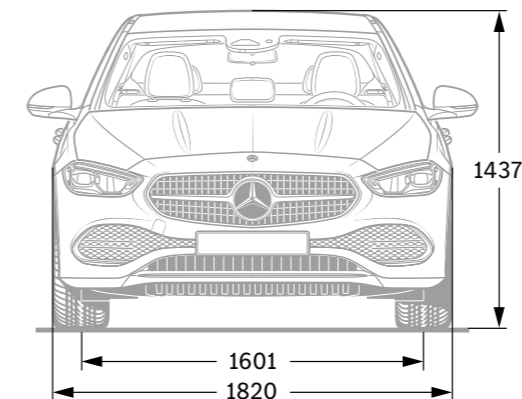

All figures in millimetres. The pictured dimensions are mean values. They are valid for vehicles with standard equipment and in unladen condition.



# SPORT — F O R — GOOD

For 20 years now it has been our belief that sport has the power to connect people and motivate them in a unique way. We have facilitated urgently needed access to our support programmes for millions of children and young people, so helping them to achieve positive change in their lives. The programmes that we support together with Laureus Sport for Good are in line with the United Nations' Sustainable Development Goals and are part of an exciting major global movement to effect positive change in the world. **In buying a Mercedes-Benz you are supporting the “Laureus Sport for Good” movement.**

**Please note:** changes may have been made to the product since the editorial deadline (03.03.2021). The manufacturer reserves the right to make changes to the design, form, colour and the product specification during the delivery period, provided these changes, while taking into account the interests of the vendor, can be deemed reasonable with respect to the purchaser. Where the seller or the manufacturer uses symbols or numbers to describe an order or the subject of an order, no rights may be derived solely from these. The illustrations may show accessories and items of optional equipment which are not part of standard

specification. This publication is distributed internationally. However, information regarding statutory regulations, legal requirements and taxation and the consequences thereof applies to the Federal Republic of Germany only and is correct at the time of the editorial deadline. For the definitive latest information, please contact your authorised Mercedes-Benz sales partner.

[www.xxxxxx.xxx](http://www.xxxxxx.xxx)