



EQE

THIS IS FOR  
ALL THE SENSES.



# THIS IS FOR ALL THE SENSES.

From the iconic one-bow design to the innovative MBUX Hyperscreen<sup>1</sup>, the EQE Saloon combines sensuous aesthetics with pioneering engineering at the highest level. Experience a new, luxurious era of electric mobility.



<sup>1</sup>Optionally selectable equipment depending on configuration.



## LUXURY ALL ALONG THE LINE.

Even at first glance it is clear: the EQE Saloon embodies a new era. The main characteristic feature is the striking one-bow design – a coupé-like shoulder line that flows sweepingly from the rear to the front, emphasising typical EQ features such as the three-dimensional Mercedes-Benz star pattern on the front.







## THE DIGITAL COCKPIT WITH FUTURISTIC MBUX HYPERSCREEN.

The MBUX Hyperscreen<sup>1</sup> is the highlight in the cockpit of the all-electric EQE Saloon: behind a curved panel in real glass are brilliant OLED displays that can be intuitively operated and which deliver innovation and brilliance across the full width of the vehicle interior.

<sup>1</sup>Optionally selectable equipment depending on configuration.





## IMPRESSIVE FRONT END WITH STAR PATTERN.

The distinctive front section in Mercedes-EQ design is characterised by a deep black radiator grille (Black Panel) and innovative headlamps. The star pattern<sup>1</sup> in a creative three-dimensional design is integrated into the radiator grille as a visual highlight.

<sup>1</sup>Optionally selectable equipment depending on configuration.



# EXCELLENT RANGE. ZERO EMISSIONS.

You're well on track in the all-electric EQE Saloon: with high ranges, short charging times and zero local emissions.





# ELECTRIC MOBILITY FOR ALL THE SENSES.

Driving with all your senses: sounds that respond dynamically to the way you drive, a sensuous mix of materials and fragancing in the interior ensure that the time you spend in the EQE Saloon is always of the highest quality.<sup>1</sup>

<sup>1</sup>Optionally selectable equipment depending on configuration.





## PERFECT RESTRAINT.

Eight air chambers and four vibration elements ensure outstanding comfort in the multicontour seats<sup>1</sup>. Ten massage programs in two intensities turn every ride into a wellness program.

<sup>1</sup>Optionally selectable equipment depending on configuration.



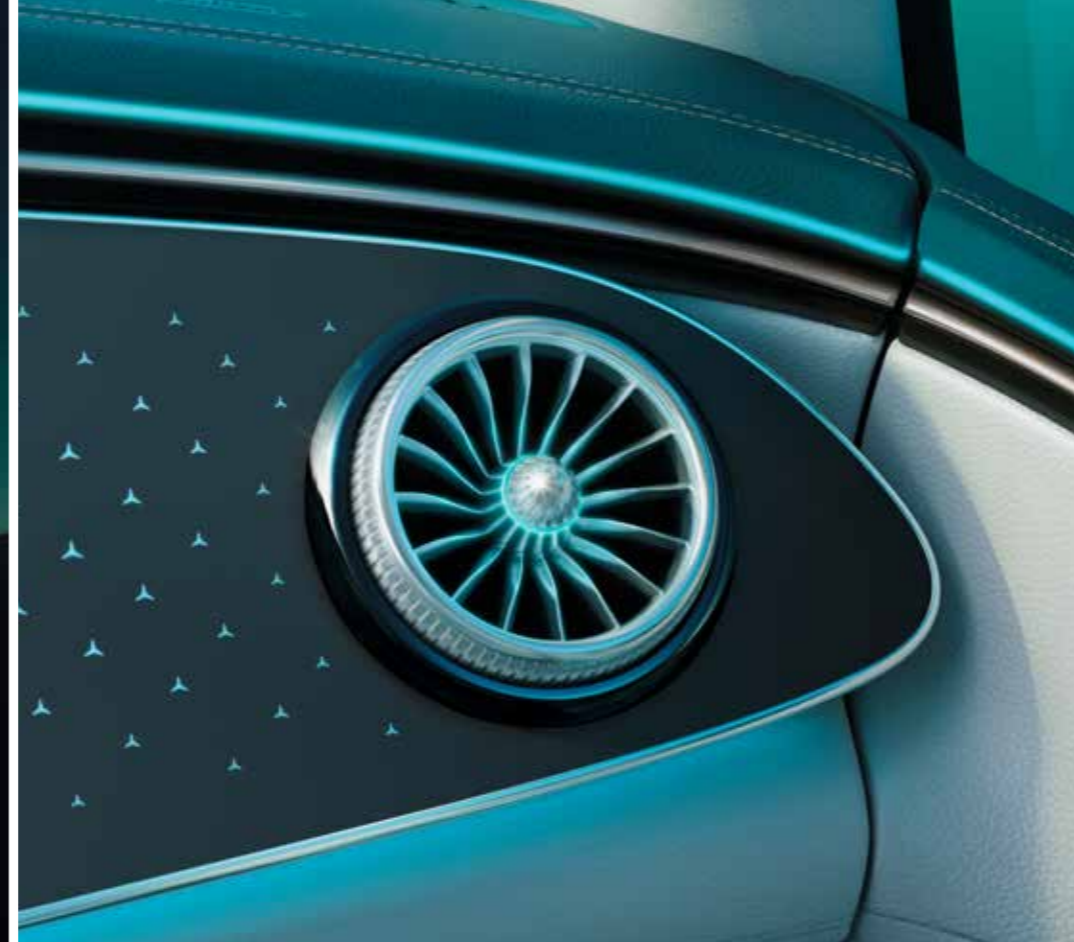

## Flush-fitting door handles.

Seamless design perfected: the flush-fitting door handles are seamlessly integrated into the vehicle body and round off the elegant appearance of your Mercedes. The handles extend automatically when you are in the immediate vicinity of the vehicle to unlock it. As soon as you lock the vehicle or drive off, the handles retract again.

## Air filter system with HEPA filter.

With a filter efficiency of up to 99.65%, the HEPA<sup>1</sup> (High Efficiency Particulate Air) fine dust filter can remove the finest particles such as pollen and fine dust from the incoming air and can neutralise unpleasant odours.

## Active ambient lighting.

Experience a technological leap with active ambient lighting<sup>1</sup>. It combines visual appeal with innovative driver information and extended functions. Wraparound light strips and trim elements amalgamate to form an additional lighting level. This also supports driving assistance systems<sup>2</sup> visually, emphasising the intelligence of your vehicle.

## DIGITAL LIGHT.

Intelligent foresight: the optional DIGITAL LIGHT<sup>1</sup> headlamp technology with projection function in the EQE Saloon complements the MULTIBEAM LED headlamps with their high-resolution lighting technology. The light acts in an anticipatory manner, adapting to the course of the road and the traffic situation.

<sup>1</sup>Optionally selectable equipment depending on configuration.

<sup>1</sup>Optionally selectable equipment depending on configuration.

<sup>2</sup>Our driver assistance and safety systems are aids and do not relieve you of your responsibility as a driver. Please take note of the information in the Owner's Manual and the system limits which are described therein.





## MBUX Hyperscreen.

Enhance your interior with an impressive design feature. As if cast from a single mould, 3 displays seamlessly blend together beneath a glass panel, creating one large hyperscreen. Bright OLED displays with haptic feedback and the innovative zero-layer interface create a particularly user-friendly experience.<sup>1</sup>

<sup>1</sup>Optionally selectable equipment depending on configuration.



## Burmester® surround sound system.

Experience greater audio performance with exquisite Burmester® sound. The high-quality speakers deliver an impressive surround sound. You can specifically optimise this for the front and rear seats to intensify the listening experience. In addition, the specially designed sound experience enhances your electric driving experience.<sup>1</sup>

<sup>1</sup>Optionally selectable equipment depending on configuration.



## AMG Line.

With the expressive styling of the AMG Line, you can lend the exterior of your EQE a fascinatingly dynamic touch. It transports sporty AMG genes into the electric business class – for example with the AMG-specific front apron and AMG light-alloy wheels.<sup>1</sup>

<sup>1</sup>Optionally selectable equipment depending on configuration.



## Electric Art exterior.

With the Electric Art exterior you impressively underscore the progressive character of your EQE: trim elements in chrome on the front and rear apron add expressively elegant highlights. In combination with the 19-inch light-alloy wheels they give an overall sense of poised self-assurance.<sup>1</sup>



## Electric Art interior.

With the Electric Art interior you experience progressive luxury with all your senses. For the seat covers, for example, there are high-quality materials such as leather and nappa leather to choose from. The ambient lighting and shapely comfort seats with elegant contour lighting create a futuristic lounge ambience.<sup>1</sup>

<sup>1</sup>Optionally selectable equipment depending on configuration.



## Night Package.

With the Night Package, your sporty exterior looks even more expressive. It includes numerous features with a black or black chrome finish. Depending on the vehicle's paint finish, this creates contrasts or flowing transitions. Whatever you choose, it always puts your individual stamp on the vehicle.<sup>1</sup>





## Technical data.

	Electric motors			4MATIC electric motors	
	XXX	XXX	XXX	XXX	XXX
<b>Electric motor</b>					
Rated output (kW [hp] at rpm)	XXX	XXX	XXX	XXX	XXX
Electric range <sup>1</sup> min.–max. (km) (WLTP)	XXX	XXX	XXX	XXX	XXX
Acceleration from 0 to 100 km/h (s)	XXX	XXX	XXX	XXX	XXX
Top speed (km/h)	XXX	XXX	XXX	XXX	XXX
<b>Consumption and emissions</b>					
Combined electric energy consumption <sup>2,3</sup> max.–min. (kWh/100 km) (NEDC)	XXX	XXX	XXX	XXX	XXX
Combined CO <sub>2</sub> emissions <sup>3,4</sup> (g/km)	0	0	0	0	0
Emissions class <sup>5</sup> /Efficiency class <sup>5</sup>	XXX	XXX	XXX	XXX	XXX
<b>High-voltage battery<sup>1</sup></b>					
Usable capacity (kWh)	XXX	XXX	XXX	XXX	XXX
Max. charging capacity DC (kW)	XXX	XXX	XXX	XXX	XXX
Max. charging capacity AC (kW)	XXX	XXX	XXX	XXX	XXX
DC charging time 10–80% SOC (net) (min)	XXX	XXX	XXX	XXX	XXX
AC charging time 10–100% SOC (net) wallbox/public 11 kW WEU (h)	XXX	XXX	XXX	XXX	XXX
AC charging time 10%–100% SOC (net) at household socket 2.3 kW (h)	XXX	XXX	XXX	XXX	XXX

<sup>1</sup> The stated figures are the determined “WLTP CO<sub>2</sub> figures” pursuant to Article 2 No. 3 of Implementing Regulation (EU) 2017/1153. Fuel consumption figures have been calculated on this basis. Electric energy consumption [and range] has/have been determined on the basis of Regulation (EU) 2017/1151. <sup>2</sup> The certified electrical consumption is generally determined at maximum AC charging capacity with a Mode 3 cable. It is therefore recommended to charge vehicles with a high-voltage battery wherever possible at a wallbox or an AC charging station using a Mode 3 cable in order to achieve shorter charging times and better charging efficiency. <sup>3</sup> The stated figures were determined according to the prescribed measurement method. They constitute the “NEDC CO<sub>2</sub> figures” pursuant to Article 2 No. 1 of Implementing Regulation (EU) 2017/1153. Fuel consumption figures have been calculated on this basis. Electric energy consumption has been determined on the basis of Regulation (EC) 692/2008. <sup>4</sup> The stated figures are the “measured NEDC CO<sub>2</sub> figures” pursuant to Article 2 No. 2 of Implementing Order (EU) 2017/1153, determined in compliance with Appendix XII of Directive (EC) No. 692/2008. Fuel consumption figures have been calculated on this basis. Power consumption has been determined on the basis of Directive (EC) No. 692/2008. Due to legal changes to the relevant test procedures, higher values may be entered in the vehicle’s certificate of conformity that is a determining factor for vehicle registration and potentially also for motor vehicle tax. <sup>5</sup> Determined on the basis of the measured CO<sub>2</sub> emissions, taking into account the mass of the vehicle. For further technical data, please visit [www.xxxxxx.xxx](http://www.xxxxxx.xxx)

## Dimensions.

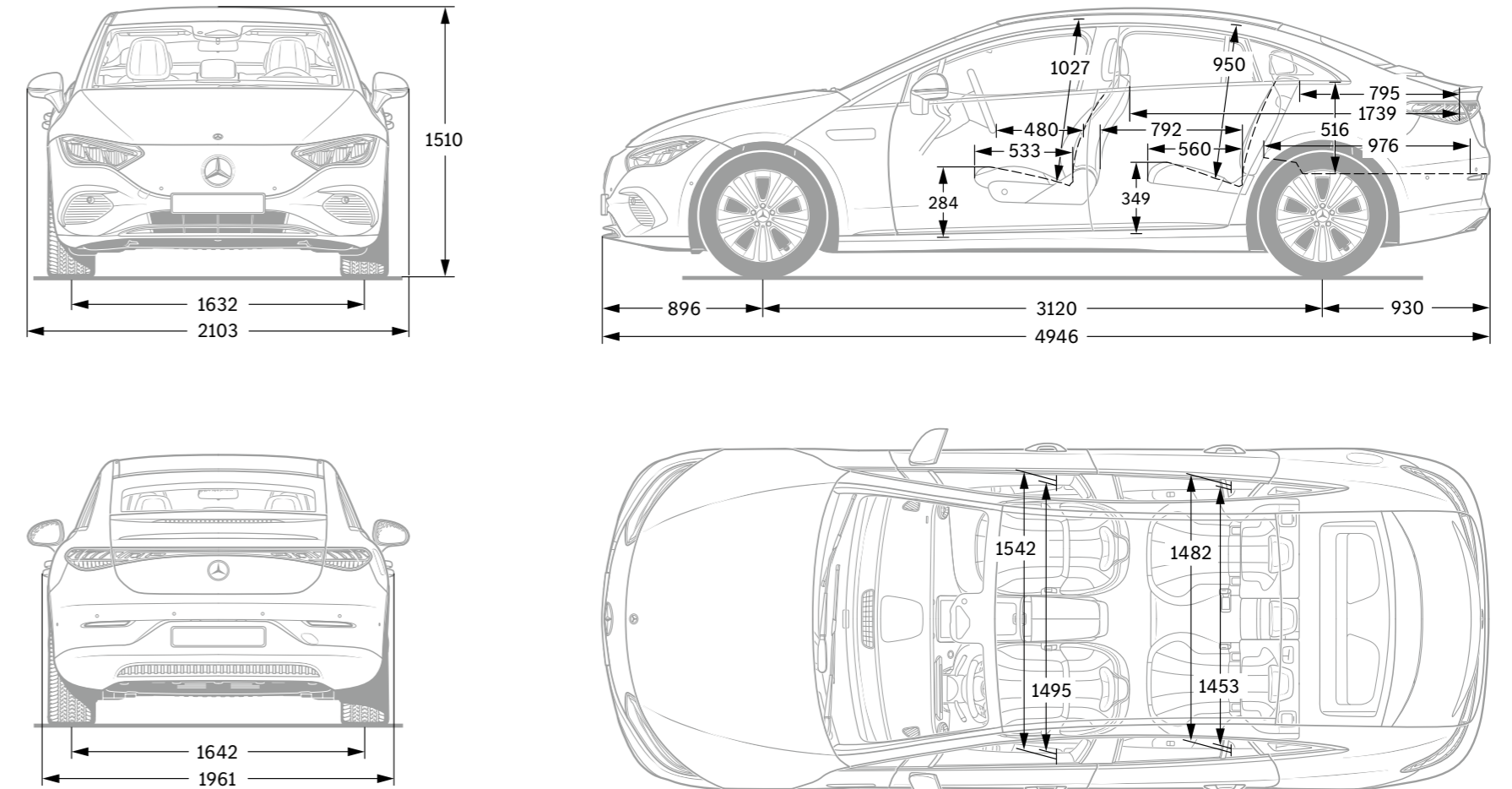

All figures in millimetres. The dimensions shown are mean values. They are valid for vehicles with standard equipment and in unladen condition.



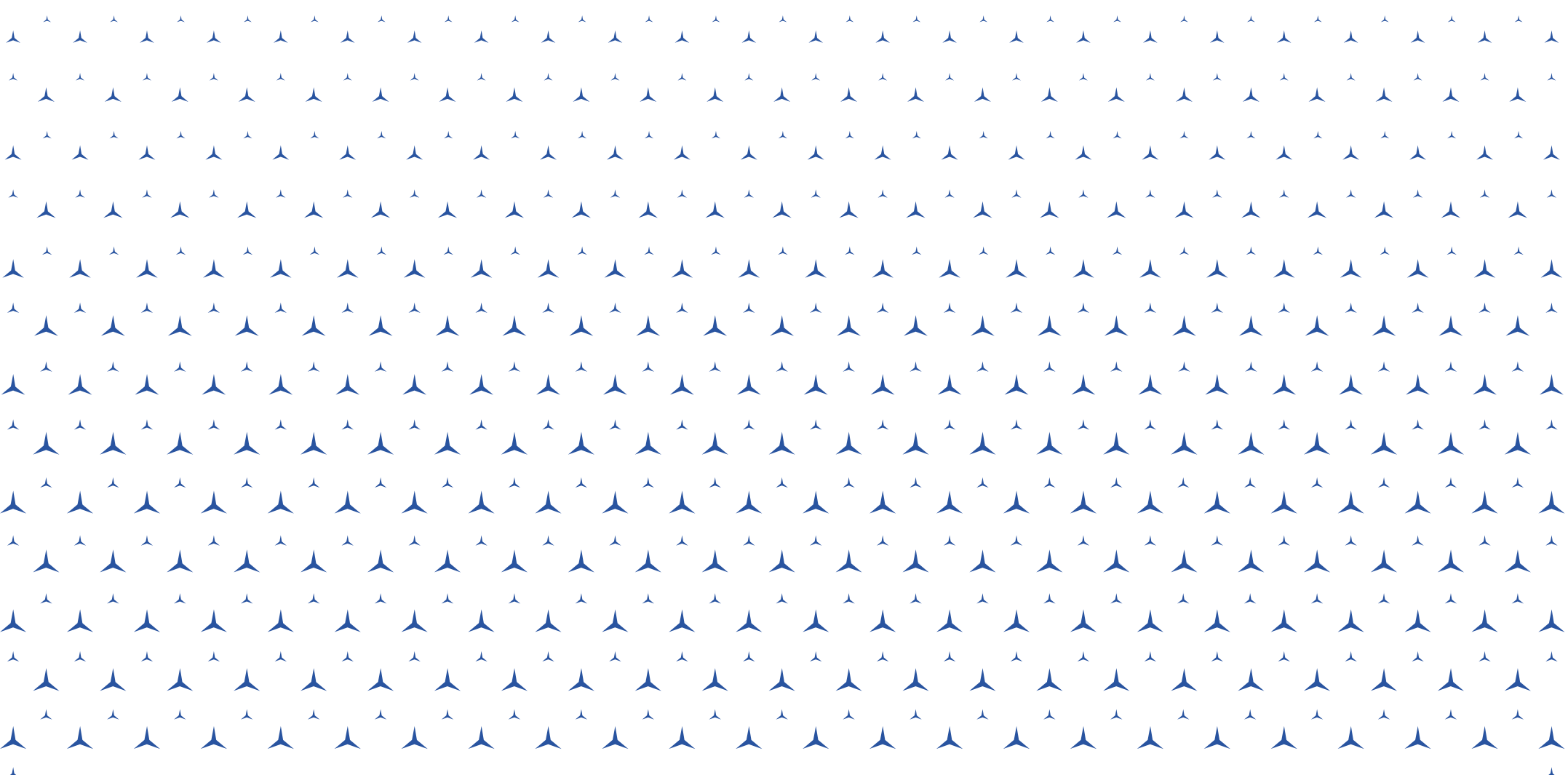

**Please note:** changes may have been made to the product since the editorial deadline (30.03.2023). The manufacturer reserves the right to make changes to the design, form, colour and the product specification during the delivery period, provided these changes, while taking into account the interests of the vendor, can be deemed reasonable with respect to the purchaser. Where the vendor or the manufacturer uses symbols or numbers to describe an order or the subject of an order, no rights may be derived solely from these. The illustrations may show accessories and items of optional equipment which are not part of standard specification.

XXXXXXX, XXXXXXXX@XXXXXX.XXX, 02-0423

This publication is distributed internationally. However, information regarding statutory regulations, legal requirements and taxation and the consequences thereof applies to the Federal Republic of Germany only and is correct at the time of the editorial deadline. For the definitive latest information, please contact your nearest authorised Mercedes-Benz AG sales partner.

[www.xxxxxx.xxx](http://www.xxxxxx.xxx)

